

NOVA Automation is thrilled to bring a reliable mobile palletizing cell to the market. It provides companies of all sizes the opportunity to palletize their product more consistently and efficiently. Our customer's just need to pick up the palletizing cell with a forklift, place it where they want, connect to power and air, and it's ready to go.

Plug. Play. Profit.

### Key Features and Options

- Ready to palletize on delivery
- No Install Required
- Place the palletizing cell with a forklift, add power, connect to compressed air, and you're all set
- System includes NOVA's safety zone scanner to provide interaction with operators during continuous operations
- Comes standard with NOVA's advance control system and pallet builder software, allowing your operators to design new patterns in minutes
- Successfully palletize cases up to 50 lbs.
- Option to palletize on both sides of the cell for increased efficiency
- Smaller, more mobile footprint than a conventional palletizer, allowing you to easily relocate within your plant if needed

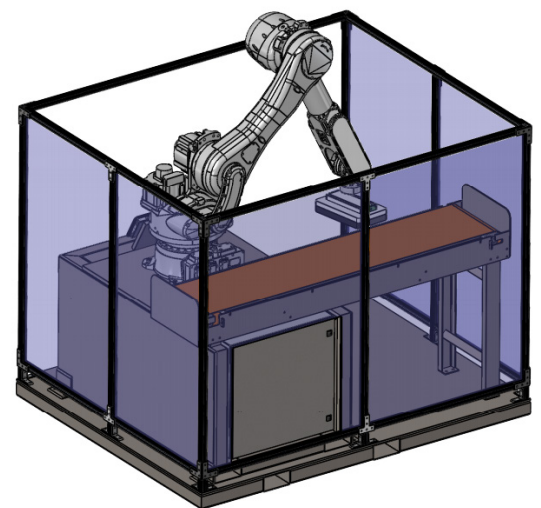
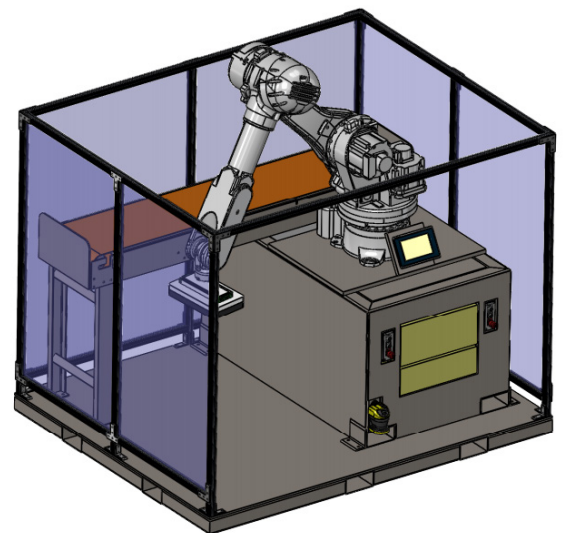

Your Process, Automated.

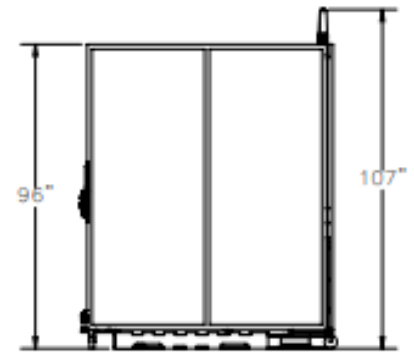
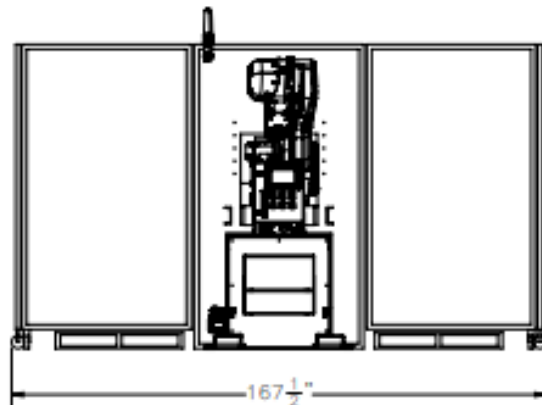
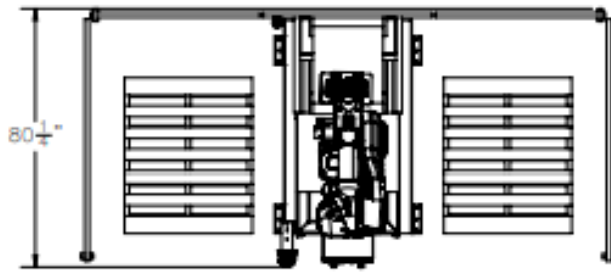

## TECHNICAL SPECIFICATIONS

<b>Product Applications</b>	Palletizing of boxes (cases)
<b>Typical Handling Rate</b>	Up to 1,560 BPH
<b>Maximum Reach</b>	Up to 3,255mm
<b>Ambient Temperature</b>	0 C to 45 C
<b>Noise Level</b>	75 db
<b>Weight Capacity</b>	180 kg to 300 kg
<b>Control System</b>	Robot controller with teach pendant and capability to integrate with PLC systems
<b>Approximate Dimensions</b>	96" x 78" x 76.5" (Single Pallet) 167.5" x 80.5" x 107" (Two Pallet)
<b>Utility Requirements</b>	15 SCFM @ 80 psi for compressed air 460VAC 3-Phase, 60hz, 30Amps power